

**CHV horizontal adjustable lifting clamps**



Adjustable lifting clamp for safe lifting and moving of packages and single plates in horizontal position. Always use these clamps per pair.

**Norm:**

- EN12100-1/2, EN13155, AS4991, ASME-B30,20

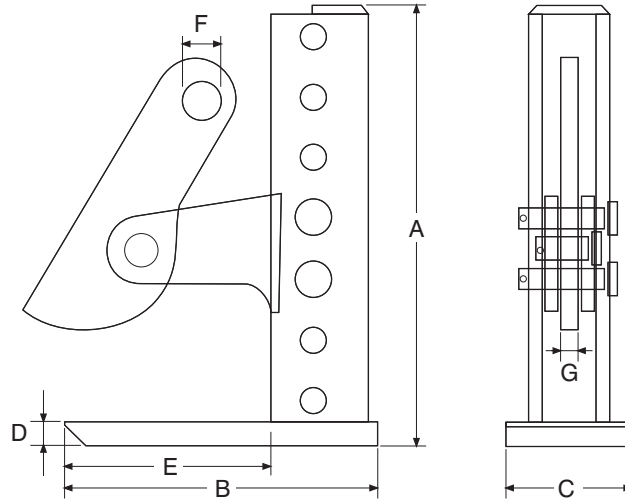

Type	WLL/pair (kg)	Jaw opening (mm)	A (mm)	B (mm)	C (mm)	D (mm)	E (mm)	F (mm)	G (mm)	Weight/pair (kg)	ProductId
CHV-1.5	1500/2	3-180	290	200	90	15	135	30	20	18/2	3315011
CHV-1.5X	1500/2	3-300	410	200	90	15	135	30	20	23/2	3315013
CHV-3.0	3000/2	3-180	300	235	105	20	165	30	20	29/2	3315015
CHV-3.0X	3000/2	3-300	410	235	105	20	165	30	20	31/2	3315017
CHV-4.5	4500/2	3-180	300	235	105	20	165	30	20	32/2	3315019
CHV-4.5X	4500/2	3-420	535	235	105	20	170	30	20	34/2	3315021
CHV-6.0	6000/2	3-180	305	250	120	25	160	30	20	40/2	3315023
CHV-6.0X	6000/2	3-420	540	250	120	25	165	30	20	46/2	3315025
CHV-9.0	9000/2	3-180	305	250	120	25	160	30	20	51/2	3315027
CHV-9.0X	9000/2	3-420	540	250	120	25	165	30	20	60/2	3315029